

litilit

INDYLIT 3

Ultracompact femtosecond laser for ophthalmology
1030 nm, 290 fs, 3 W, 1 – 3 MHz

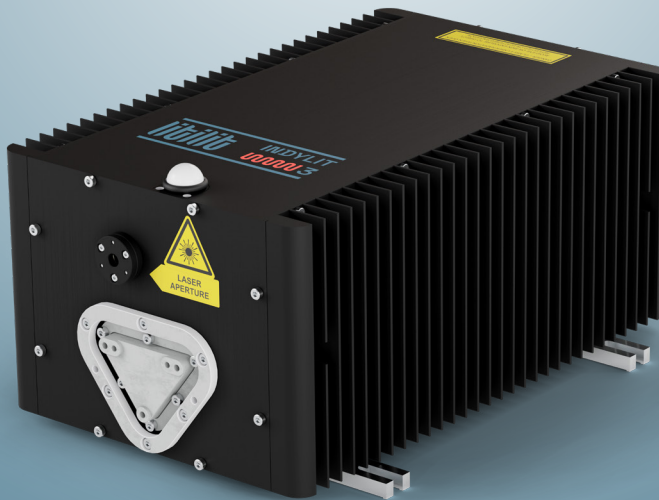

WWW.LITILIT.COM

ULTRACOMPACT, ROBUST AND MAINTENANCE FREE

FEATURES

- Extremely robust and stable
- Ultracompact, passively cooled with very low power dissipation
- Excellent beam and pulse quality
- Maintenance-free & turn-key
- Dust and water protection IP51

APPLICATIONS

- Ophthalmology
- Photopolymerization
- Semiconductor and electronics

INDYLIT 3

The **Indylit 3** is an ultra-compact femtosecond laser with moderate average power and pulse energy, optimized for ophthalmology applications such as the SMILE procedure. Laser offers excellent pulse and beam quality, which, along with its robustness, makes it the perfect choice for ophthalmology applications.

The laser head is highly compact, lightweight yet robust, and has very low heat dissipation (~10W). It is also dust and water protected (class IP51) and operates within a broad temperature range (18-32°C) and has an integrated pulse-picker, making integration simple even in the most tight and demanding environments.

SPECIFICATIONS

Model	Indylit 3
Central wavelength	1030 ± 3 nm
Average power ¹⁾	> 3 W @ 3 MHz
Max. pulse energy ¹⁾	> 2 µJ @ 1 MHz > 1 µJ @ 3 MHz
Pulse duration	< 290 fs
Pulse duration tunability	290 fs – 5 ps
Internal pulse repetition rate	1 MHz - 3 MHz down to 300 kHz in burst mode
Pulse picker	Integrated
Pulse control mode	Pulse picker control via TTL gate signal (selectable gate or trigger mode)
Burst length	1...10 pulses
Max. energy in burst	> 10 µJ @ 300 kHz
Power attenuation ²⁾	100 – 1 %
Beam quality	M ² < 1.2
Beam circularity ³⁾	> 0.90
Beam diameter (at 1/e ² level)	1.5 ± 0.2 mm
Polarization	Linear horizontal, > 1000 : 1 extinction
Prepulse contrast	> 1 : 1000
Post pulse contrast	> 1 : 100

Model	Indylit 3
Beam divergence (full angle)	< 1 mrad
Beam pointing (RMS) ⁴⁾	< 20 μ rad
Beam pointing vs temperature	< 15 μ rad/°C
Power stability (RMS) ⁵⁾	< 1 %
Pulse energy stability (RMS) ⁶⁾	< 1 %
Warm-up time (cold start)	< 10 min
Warm-up time (warm start)	< 3 min
Laser control interface	CAN, USB
Operating voltage	24V, 15A (100...240 V AC, 47...63 Hz to 24V AC/DC converter included)
Average power consumption (after warm-up)	100 W
Maximal power rating	300 W
Operating temperature	18 – 32 °C
Humidity	Non-condensing
Transportation/storage temperature	-20 – +70 °C
Dimensions: Laser head (L x W x H) Control unit (L x W x H) AC/DC converter (L x W x H)	301 x 189 x 156 mm 449 x 385 x 140 mm 250 x 125 x 60 mm
Umbilical length	3 ± 0.2 m
Cooling: Laser head Control unit	air (passive) forced air (fans)

¹⁾ Laser power is approximately constant in the 1-5MHz operation range. Pulse energy is therefore inversely proportional to the repetition rate.

²⁾ Attenuation can be controlled by a few different methods: a) by PC user interface, b) by CAN register, c) by analog input (0-1V, rise time <1 μ s). Beam quality specifications are maintained down to 10% power level.

³⁾ Defined as the worst case ellipticity along the z-scan ($\pm 5 \times L_{\text{Rayleigh}}$) of the beam.

⁴⁾ Measured during 8h operation starting 30 minutes after cold start. Environmental temperature stability within $\pm 1^\circ\text{C}$.

⁵⁾ Measured with integration time of 1s at the same conditions as (4).

⁶⁾ Measured within 10s time interval for at least 1000 pulses.

⁷⁾ Technology is protected by international patents: LT6261 (B); JP6276471 (B2); US10038297 (B2); EP3178137; DK3178137 (T3); CN106575849 (B); PL3178137 (T3); LT6639 (B); LT2020 563.

CE RoHS

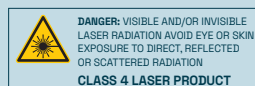

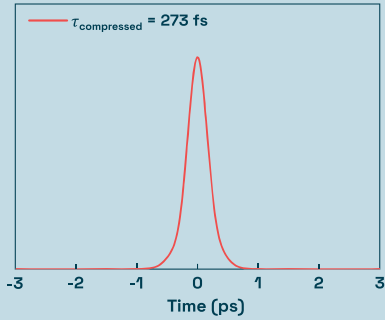

Pulse autocorrelation traces of optimally compressed pulses

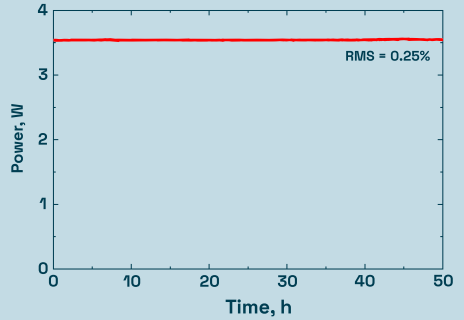

Long term output power stability

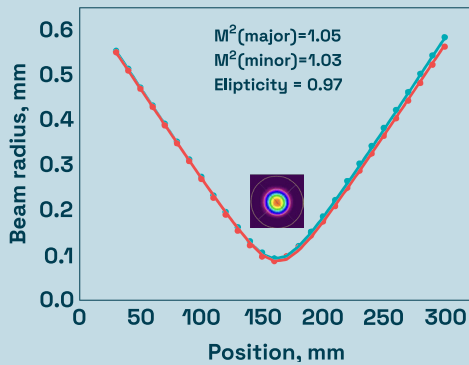

Beam z-scan measurement and beam profile in far field

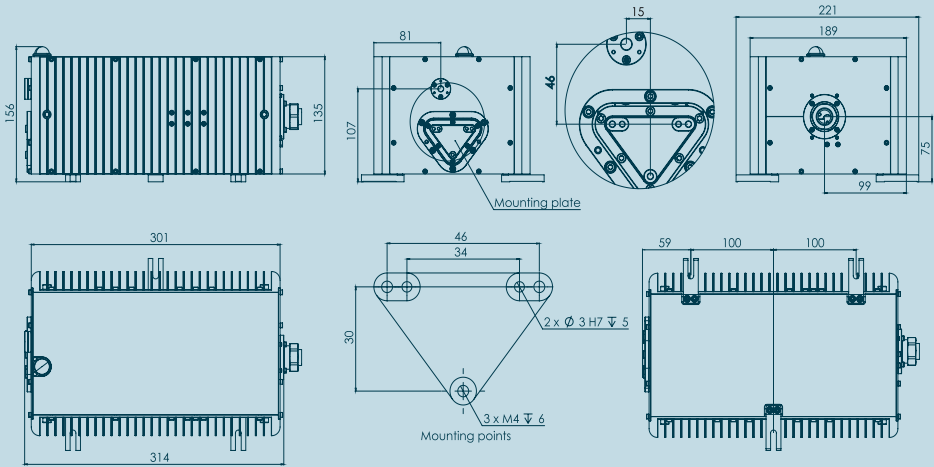

Drawing of Indylit-3 laser head (in mm)

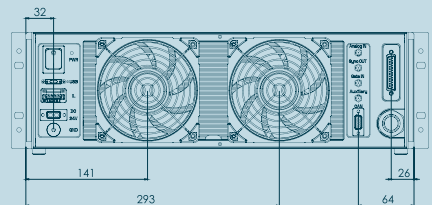
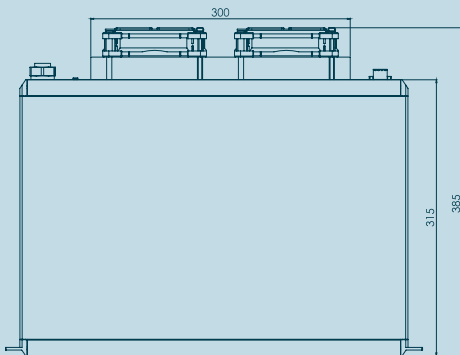
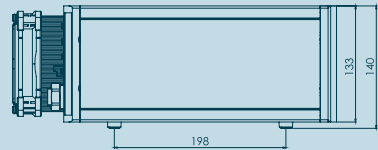
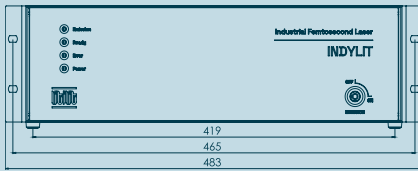

Drawing of Indylit-3 control unit (in mm)

