

litolit

BIOLIT 2

Femtosecond Fiber Laser for Biophotonics
1050 nm, 70 fs, 2 W, 20 MHz

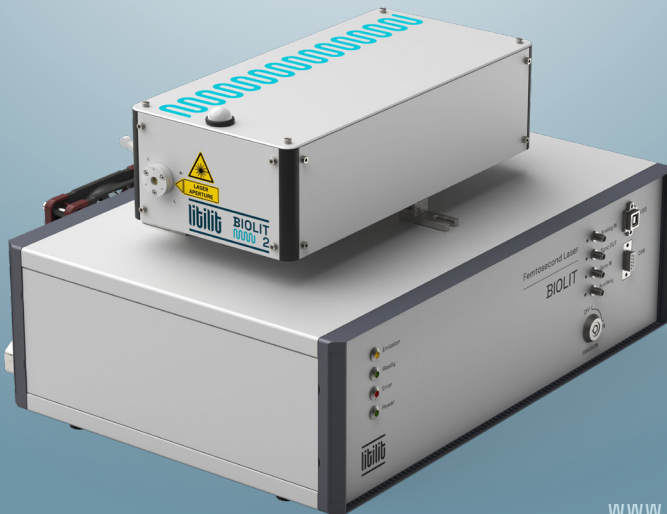

WWW.LITILIT.COM

CLEAN PULSES LEAD TO SHARP IMAGES

FEATURES

- Ultra-short and clean pulses
- Robust and stable
- Flexible repetition rate
- Maintenance-free & turn-key
- Integrated dispersion pre-compensation

APPLICATIONS

- Multiphoton microscopy
- Neuroscience
- Photopolymerization
- Ophthalmology
- OPO pumping

BIOLIT 2

The **Biolit 2** is a compact, air-cooled femtosecond laser designed for multiphoton microscopy, biophotonics and other non-linear optics applications. The industrial-grade device is exceptionally robust, maintenance-free and affordable. A combination of ultra short (typ 55 fs) and clean pulses with integrated dispersion compensation, excellent beam quality and optimized repetition rate enables unparalleled quality multiphoton imaging while preserving the object.

SPECIFICATIONS

Model	Biolit 2
Central wavelength	1050 ± 5 nm
Average power	> 2 W
Pulse duration	< 70 fs (typ. 55 fs)
Pulse duration stability ¹⁾	< ± 3 fs
Pulse strehl ratio	> 0.9
Tunable dispersion pre-compensation ²⁾	-6 000 fs ² ... +500 fs ²
Pulse repetition rate	20 MHz
Analog power control	1 – 100 %
Beam quality	M ² < 1.2 (typ. 1.05)
Beam circularity ³⁾	> 0.9 (typ. 0.94)
Beam diameter (1/e ² level)	1.5 ± 0.3 mm
Beam divergence (full angle)	< 1.5 mrad
Beam pointing (RMS) ¹⁾	< 20 µrad
Beam pointing vs temperature	< 15 µrad/°C

Model	Biolit 2
Pulse Energy Stability (RMS) ⁴⁾	< 1 %
Power Stability (RMS) ¹⁾	< 1 %
Warm up time (cold start)	< 10 min
Available control interfaces	USB, CAN
Operating voltage	24V, 8A (100...240 V AC, 47...63 Hz to 24V AC/DC converter included)
Operating temperature	18 – 30 °C
Humidity	Non-condensing
Transportation/storage temperature	- 20 – +70 °C
Dimensions: Laser head (L × W × H) Control unit (L × W × H) AC/DC converter (LxWxH)	313 × 152 × 107 mm 449 × 370 × 140 mm 250 × 125 × 60 mm
Cooling: Laser head Control unit	air (passive) forced air (fans)
Umbilical length	3 ± 0.1 m

¹⁾ Measured during 8 h operation starting 30 minutes after warm-up. Environmental temperature stability within ± 1 °C.

²⁾ Equivalent of 80 mm of SF10 glass.

³⁾ Defined as the worst case beam ellipticity along the z-scan ($\pm 5 \times L_{\text{Rayleigh}}$) of the beam.

⁴⁾ Measured within 10 s time interval.

⁵⁾ Technology is protected by international patents: US10038297, JP6276471, EP3178137, CN106575849.

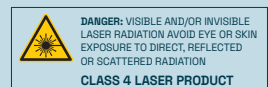

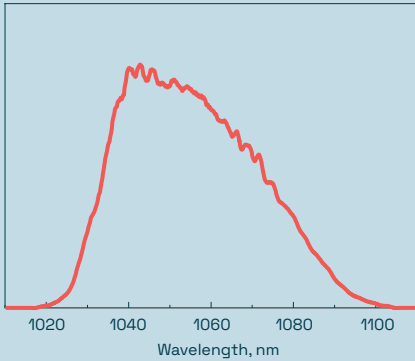

Output spectrum from **Biolit 2** laser

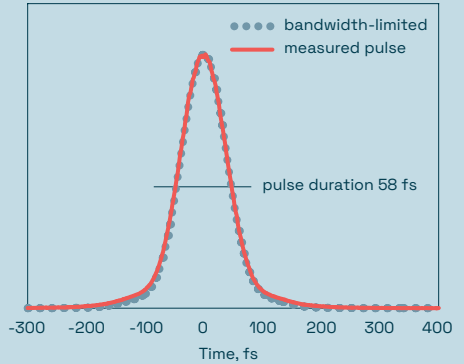

Measured autocorrelation function of the pulses from **Biolit 2** laser

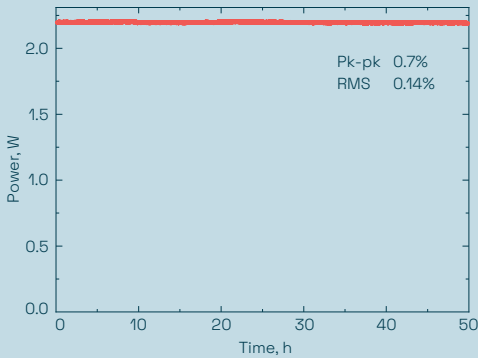

Long term power stability of **Biolit 2** laser (at 1050 nm)

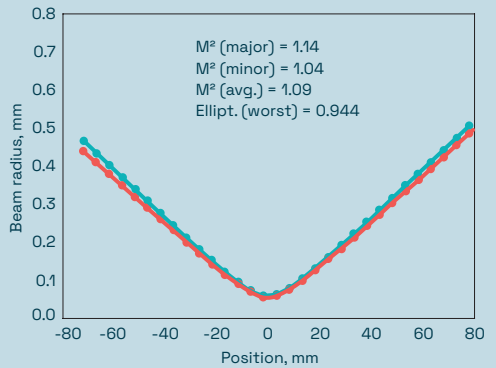

Beam diameter dependence on propagation distance (z-scan) of **Biolit 2** laser and M^2 fit

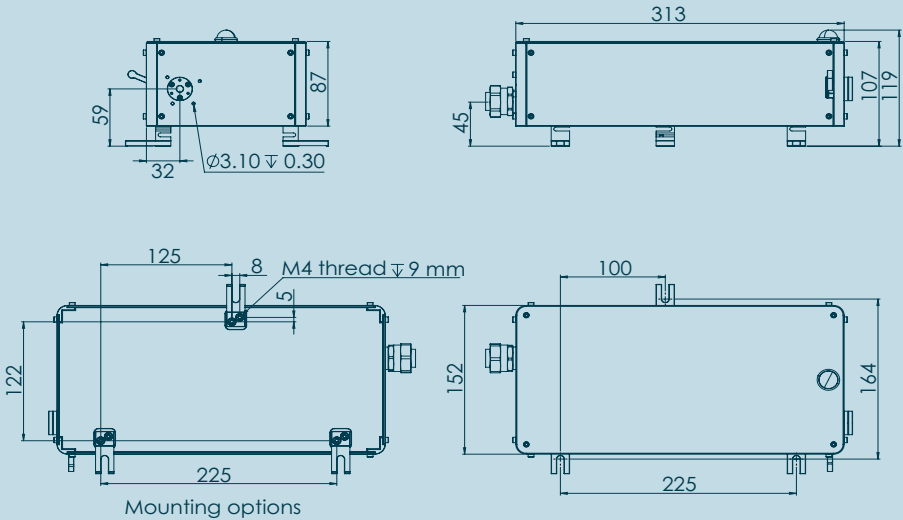

Drawing of Biolit 2 laser head (in mm)

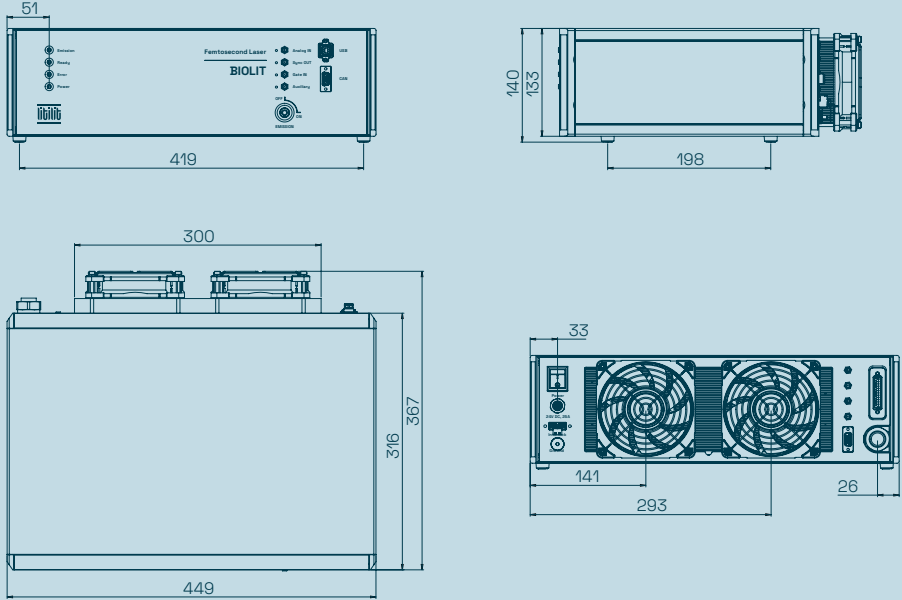

Drawing of Biolit 2 control unit (in mm)



